

Montagehandleiding

YOUP04-05

Elektrisch zit sta hoekbureau Rechts



Benodigd gereedschap

Schroefmachine

Rolmaat

Kruiskopbit

Inbus/bitje 3-4-5

Artikellijst

Doos 1

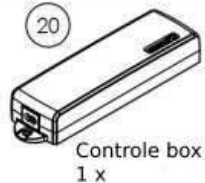
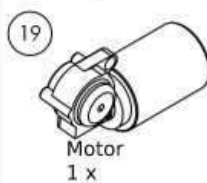
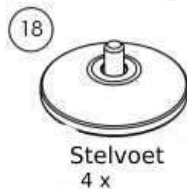
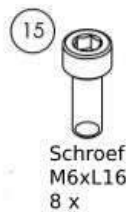
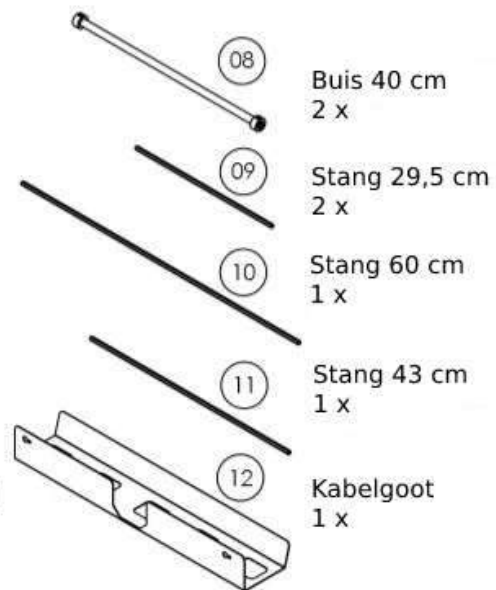
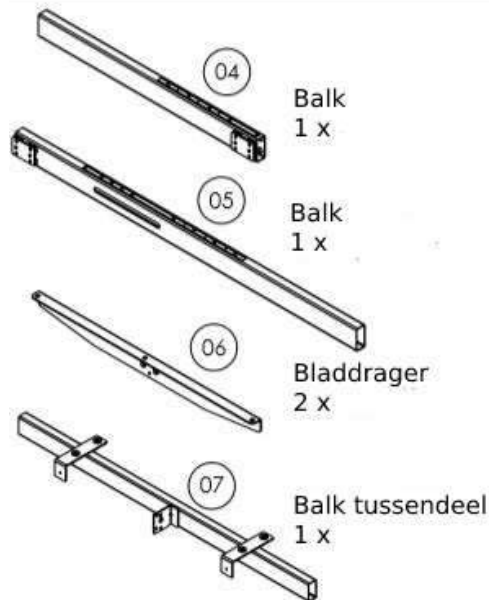
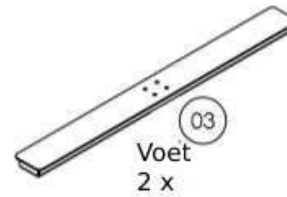
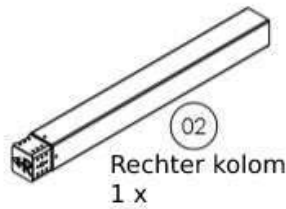
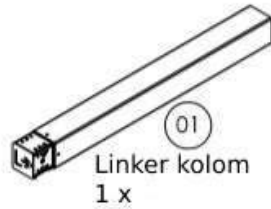

Doos 2

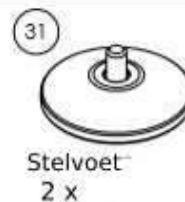
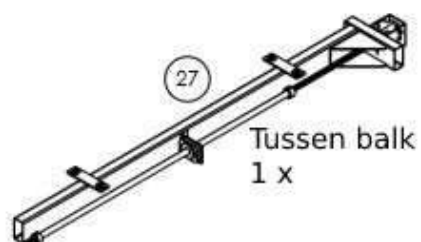
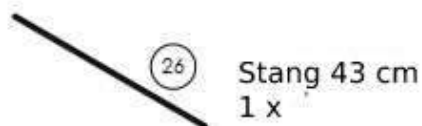
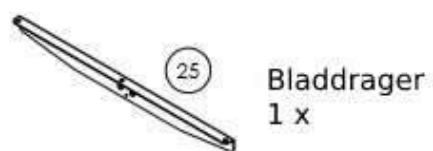
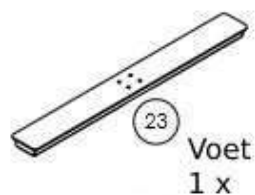
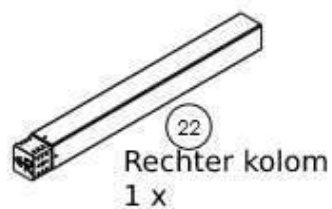

Blad
2x

Ronde zit
Verbindings-
drager
1x

Rechte zit
Verbindings-
plaatje
2x

Stap 1: controle

Maak uw pakket doos 1 en 2 open en controleer of de inhoud van uw pakket volledig is.

Stap 2: monteer linkerpoot

Doos 1, monteer volgens onderstaande tekening

A)

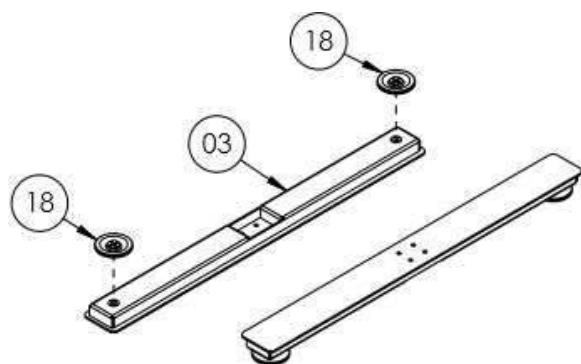

B)

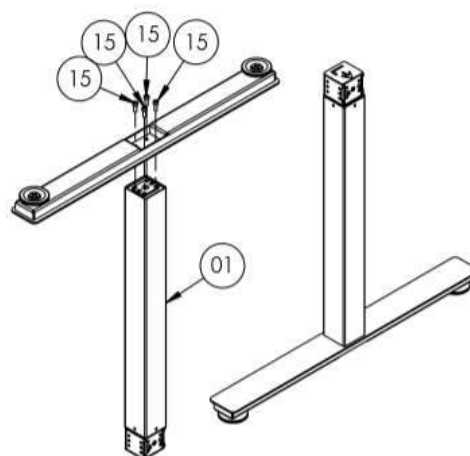

C)

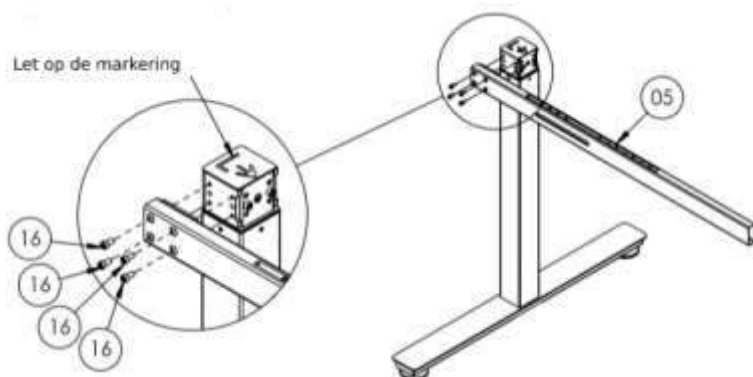

Stap 3: monteer rechterpoot

Doos 1, monteer volgens stap 2 met rechterkolom 02 en met balk 04 en markering R (=rechts)

Stap 4: monteer kleine poot

Doos 2, monteer kleine poot volgens tekening

A)

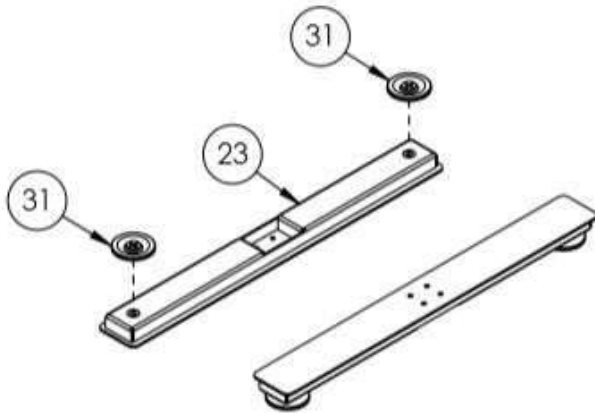

B)

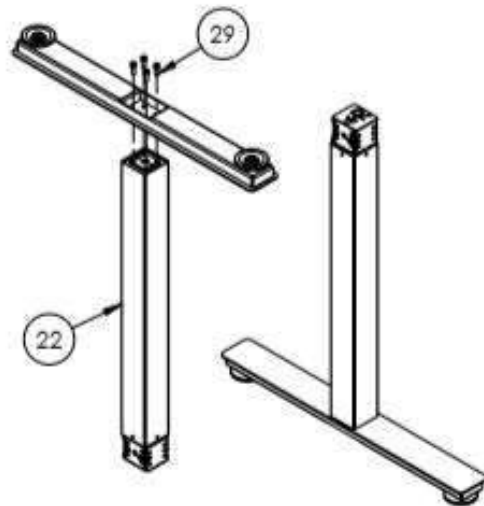

C)

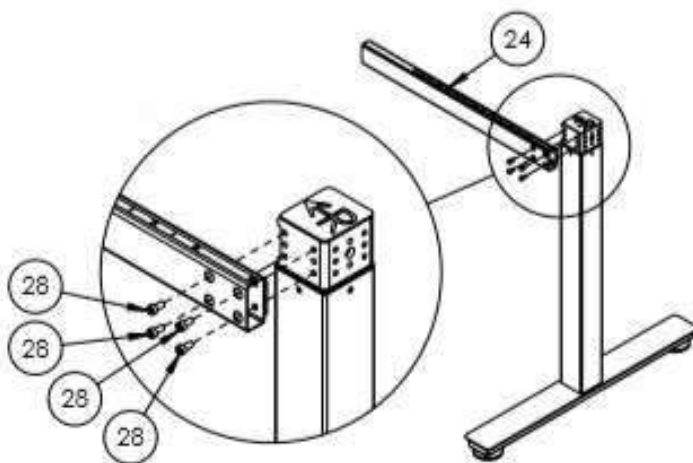

Stap 5: monteer de poten aan elkaar

- A) Monteer eerst de rechterpoot aan tussenbalk (let op: volg eerst figuur A)
- B) Installeer de motor nummer 07
- C) Monteer de Linkerpoot
- D) Check de juiste maten in Technische sheet
- E) En zet vast met schroeven M6 (8x)

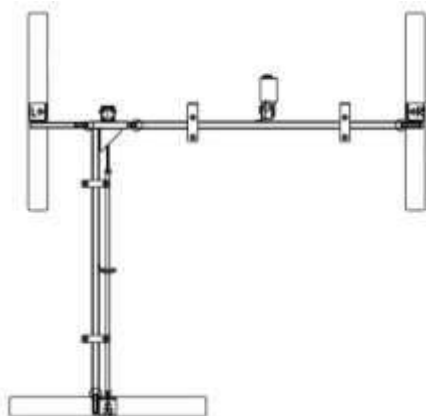
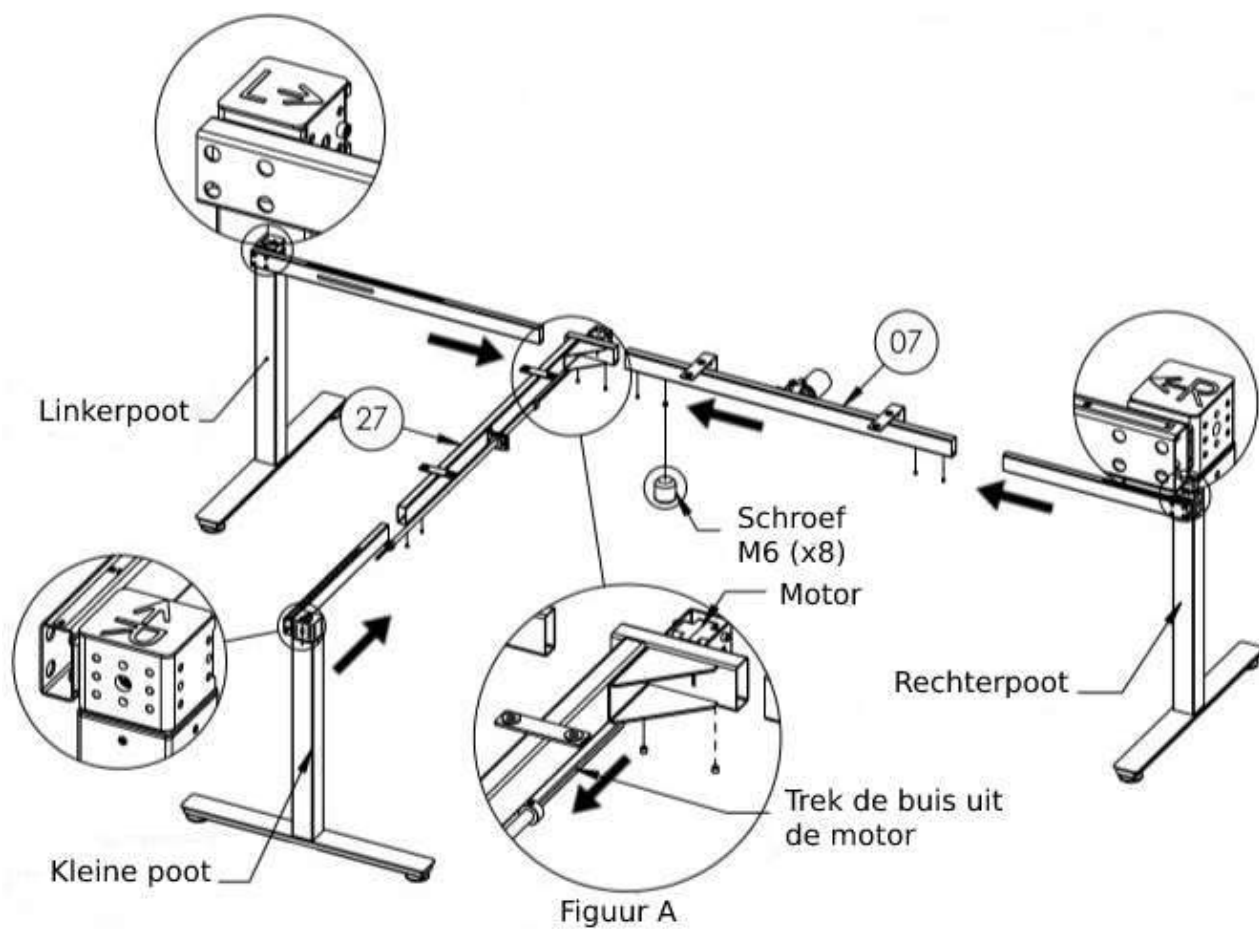

Stap 6: installeer de motor

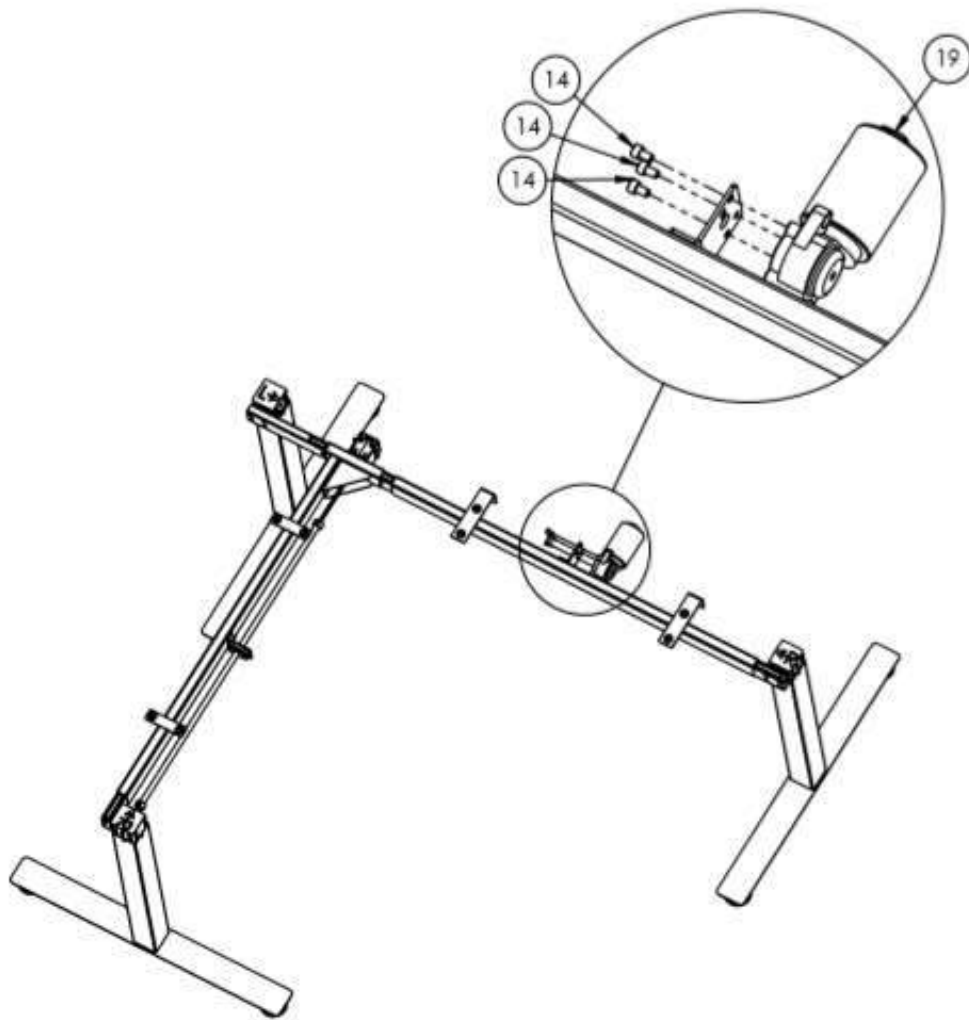

Stap 7: installeer aandrijfbuis en -stang

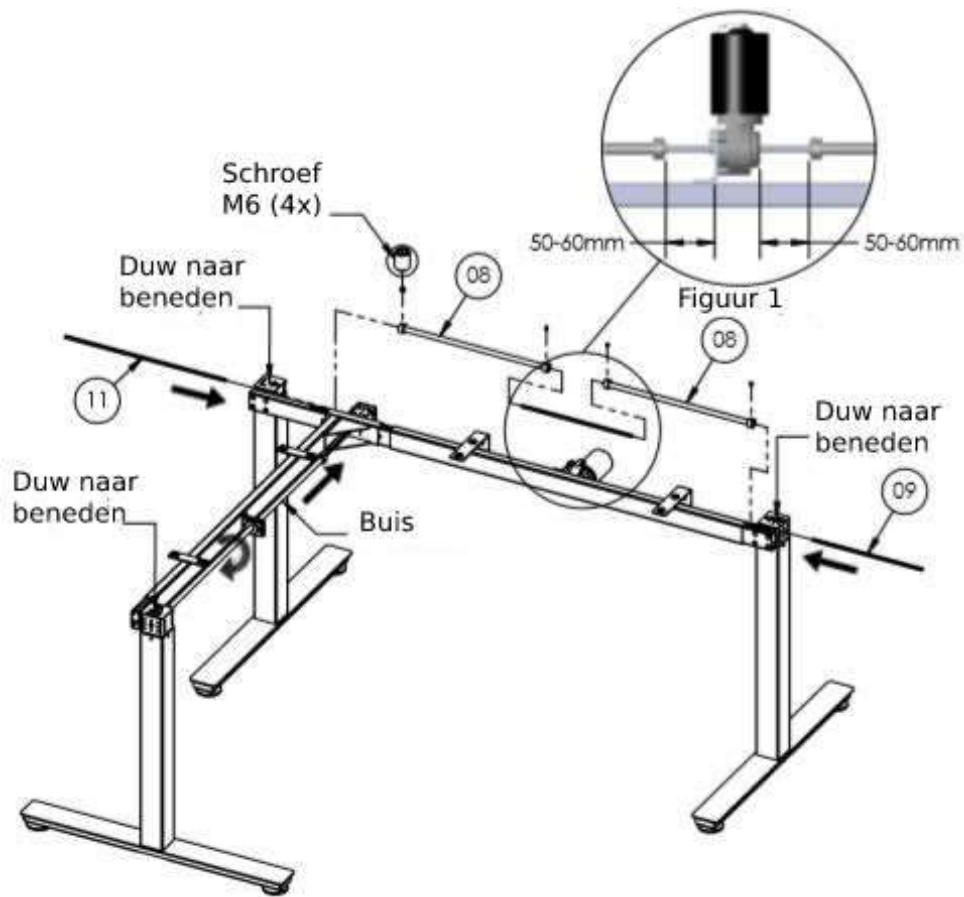

- Voor het installeren van de stang, is het belangrijk dat de linker- en rechterpoot in de laagste positie staan
- Na het installeren van stang 9, 10, 11 en buis 8, zie figuur 1 voor het installeren en afstellen van de motor
- Druk de buis in de motor en zet vast met 4 schroeven M6



Stap 8: monteer de bladragers, kabelgoot en bediening

A)

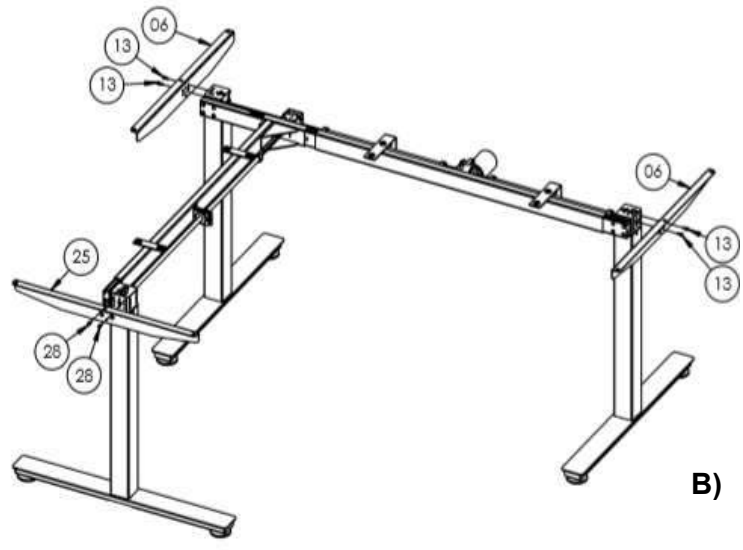

B)

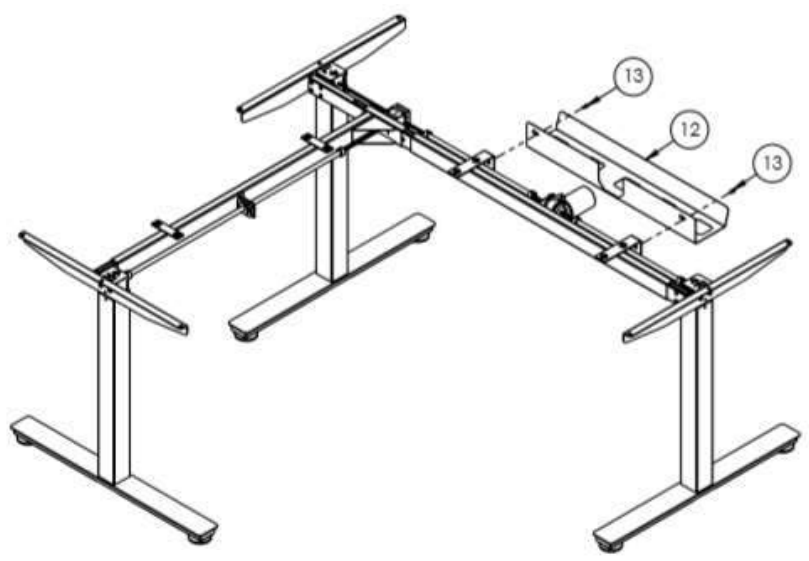

C)

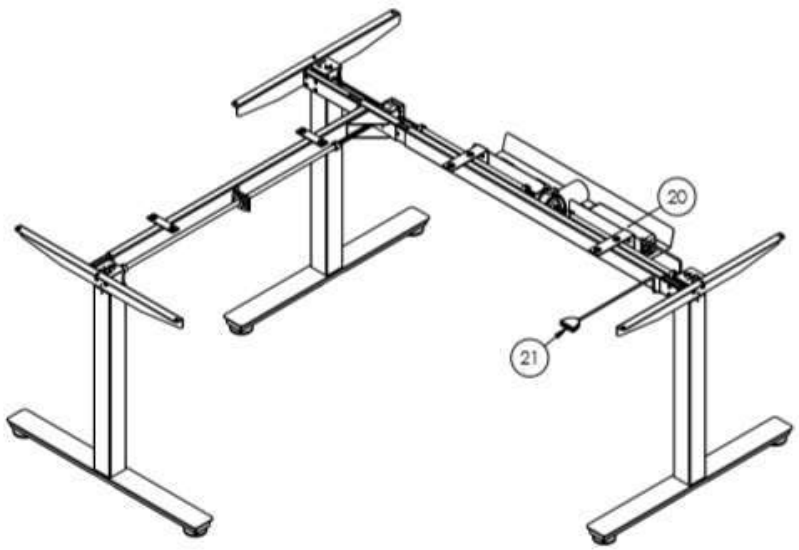

Stap 9: monteren frame aan blad

Zie technische sheet voor de juiste maten. Zorg dat het frame op de juiste manier op de bladen liggen. Monteer het frame aan het blad, per bladdrager worden er 3 schroeven gebruikt en 4 voor middenbalk. Monteer de verbindingsplaatjes/-drager volgens tekening.

Stap 10: monteren bedieningsknop aan blad

Monteer de bediening onder het blad.



Stap 11: resetprocedure voor gebruik

Belangrijk:

Zorg dat alle kabels bevestigd zijn aan de control box

Reset procedure bij in gebruik name

- Druk beide buttons (op en neer) tegelijk in, voor meer dan 3 sec. en blijf beide indrukken tot het bureau langzaam naar beneden gaat tot de laagste positie en er een geluid ontstaat. De reset is nu klaar.

Mocht er tijdens het gebruik van het bureau onverhoopt een stroomstoring zijn of een andere calamiteit, dan kunt u deze resetprocedure herhalen.

Belangrijk: Max 2 min. ON/18 min. OFF

Advies is om deze resetprocedure te bewaren

Klaar, veel plezier met uw aankoop!

Technische sheet

200x160 Rechts met ronde zit

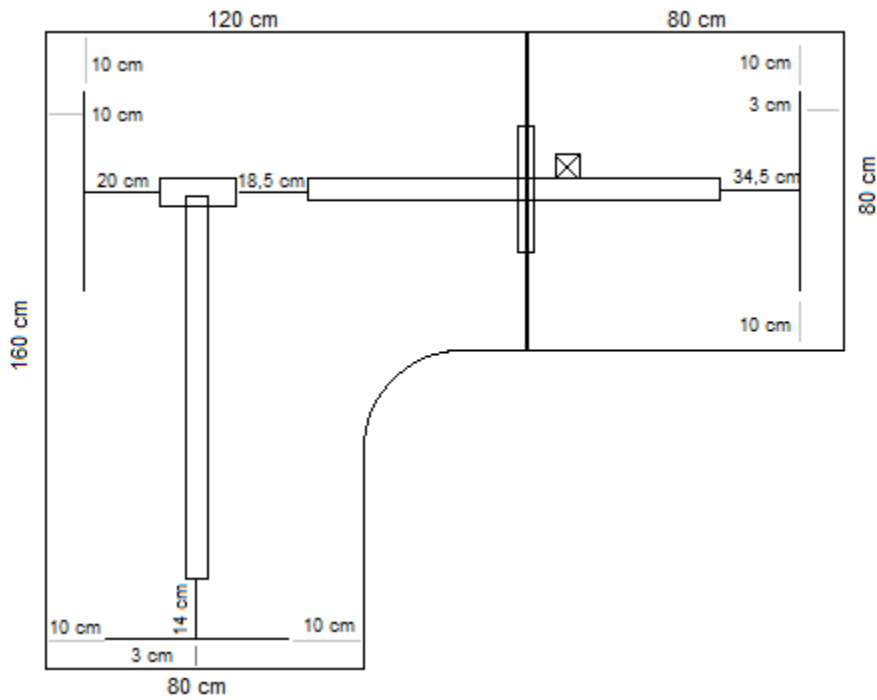

240x160 Rechts met ronde zit

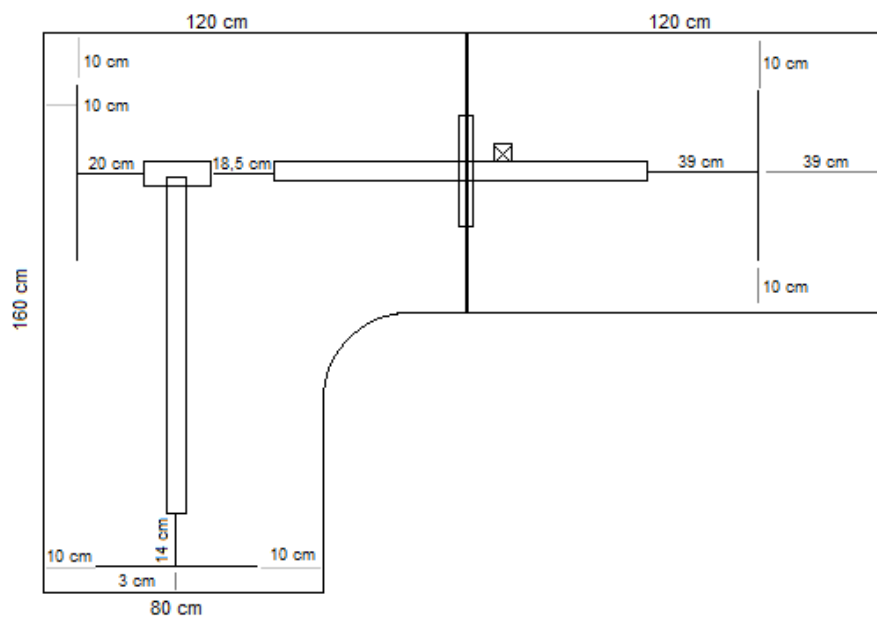

180x170 Rechts met rechte zit

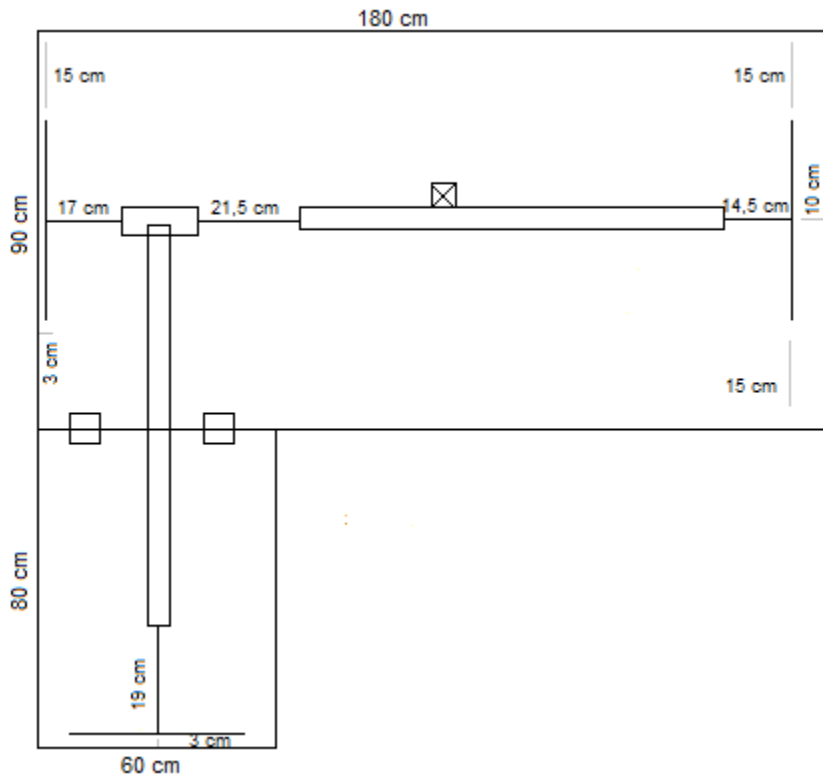

200x180 Rechts met rechte zit

